

ALITA® LINEAR AIR COMPRESSORS

INSTRUCTION MANUAL

MODELS

AL-30, AL-40, AL-60, AL-80,
AL-100, AL-120, AL-125, AL-150, AL-200, AL-250E,
AL-250, AL-300, AL-350, AL-400, AL-500



AL-30 ~ AL-80



AL-40P ~ AL-100P



AL-250 ~ AL-500



AL-100 ~ AL-250E



Thank you for purchasing this ALITA product.

Please read this manual in its entirety before operating the pump.

Our air pumps are designed to ensure safety when used properly. It is the responsibility of the user to follow safety-related warnings, cautions, notes and other requirements described in this manual.

Alita Industries has made every effort to ensure the correctness and completeness of the materials in this document. Alita Industries shall not be liable for errors contained herein. The information in this document is subject to changes without notice. Alita Industries shall not be liable for any errors or for incidental or consequential damages in connection with the furnishing, performance, or use of this document. Alita Industries makes no warranty of any kind with regard to this material, including, but not limited to, the implied warranties of merchantability and fitness for a particular purpose.

Revision G, January 2017

Copyright © 2017, Alita Industries, Inc. All rights reserved.

SAFETY INSTRUCTIONS

WARNINGS: To reduce the risk of serious or fatal personal injury or property damage, basic safety precautions should always be observed including the following:

READ AND FOLLOW ALL SAFETY INSTRUCTIONS

1. Pump only clean, dry air.
2. Ambient air temperature should not exceed 40°C or 104°F.
3. This oil-less air pump require NO lubrication.
4. Place pump away from any source of oil fume or grease vapor.
5. Do not operate pump in the vicinity of flammable or combustible materials, liquids or gases.
6. Do not operate pump if it has been inundated by water.
7. Avoid electric shock resulting from water back-siphoning, install pump above the water level of the specific application.
8. Do not operate pump if it has a damaged power cord or power plug.
9. Operate the pump only in fully assembled state.
10. Connect pump only to a terminal with GFCI (see Electrical Safety).
11. Keep power cord away from heated surfaces, sharp corners, wet locations and area of high foot traffic.
12. Reduce the risk of bursting by only use air handling devices rated for pressure no less than 55 kPa or 8 psi.

INSTALLATION GUIDELINES

Place the pump upright securely on a dry and stable surface that is easily accessible. Avoid low-lying areas susceptible to flash flooding. For aeration applications, the pump must be installed above the water surface level.

PROPER VENTILATION

Allow ample clearance around the pump for free air circulation. Proper ventilation ensures better heat dissipation which lowers internal operating temperature and prevents thermal stress to key components.

For outdoor installations, select shaded area that shelters from excessive weathering. Do not allow pump to swelter under intense sunshine or overheat within poorly ventilated enclosure. When protective enclosure is required, avoid designs that can cause thermal

insulation. Install forced ventilation system to improve rate of heat dissipation and pump reliability.

Indoor installations may also require forced ventilation when the forces of air pressure and gravity are not enough to circulate air through a room or building.

PLUMBING

Incorrect sizing of air pipe or air tubing can cause unsatisfactory performance. Utilize air pipe or tubing that are equal or larger than the pump discharge port. Matching pipe fittings should be used to reduce frictional losses.

When selecting or constructing an air manifold, the number of outlet fittings and their orifice size must be considered carefully to minimize frictional losses. Do not over regulate for extended periods. Add bleed valve to release excess flow rate and attach an air diffuser as silencer or muffler.

ELECTRICAL SAFETY

Form a drip loop with the power cord to reduce the possibility of electrical receptacle getting wet. A drip loop is that part of the cord hanging below the level of receptacle or the connector if an extension cord is used.

In the event of an electrical short circuit, grounding reduces the risk of electric shock by providing an escape wire for the electric current. This pump is equipped with a cord having a grounding wire with an appropriate grounding plug. The plug must be plugged into an electrical terminal that is properly installed and grounded in accordance with all local codes and ordinances. Do not modify the plug provided; if it does not fit the outlet, have the proper outlet installed by a qualified electrician.

Connect the pump only to a terminal with **Ground Fault Circuit Interrupter (GFCI)** installed. This device should serve to interrupt the flow of electric current in the event of ground faults (electrical current that unintentionally flows to ground). Check proper operation of GFCI every month, and replace faulty GFCI immediately.

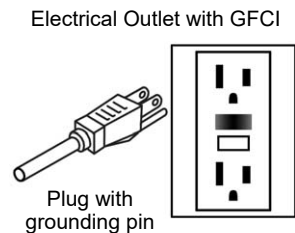

EXTENSION CORD

If an extension cord is required, use only a 3-wire extension cord that has a 3-blade grounding plug, and a 3-slot receptacle that accepts the plug on the pump. Be sure to use one heavy enough to carry the current the pump draws. For lengths less than 50 feet, No. 16/3 AWG extension cord shall be used. An undersized cord can result in a drop in line voltage, loss of power and overheating. Replace any damaged extension cord immediately.

STORAGE

Pump not in use should be stored indoors, in dry area out of the weather. Clean air filter pad and remove debris from pump surfaces before storage.

MAINTENANCE INSTRUCTIONS

Periodic pump maintenance is required for reliable continuous operation. Any maintenance of the pump other than those described herein this manual must be performed by an authorized service facility.

CAUTION: Always turn off the power and unplug from electrical terminal before any maintenance. Failure to observe this precaution can result in serious accident.

AIR FILTER pad under the filter cover should be cleaned every 3 to 6 months. Wash the filter pad gently in mild, soapy water then rinse thoroughly. Allow filter pad to dry completely before reinstalling.

If air filter pad is laden with grease residue, replace diaphragm module immediately and relocate air pump away from source of oil or grease vapor.

MAGNETIC BAR or rod located at the center of the pump may become damaged after diaphragm failure. It can also be damaged by distortion to the diaphragms due to high core temperature from poor pump ventilation. If the magnetic bar suffered damages, order a new magnetic bar along with the diaphragm replacement kit.

Magnetic bar can be demagnetized after random power spike in the electrical line or plugged into a wrong voltage supply. Replace with new magnetic bar when performance drop is unrelated to physical deterioration of diaphragm module.

DIAPHRAGM MODULE replacement cycle may differ from application to application. Replacement is typically recommended for every 24 ~ 36 months of operation. In mission critical applications, it is prudent to perform the maintenance before actual diaphragm failure.

Diaphragm Module Replacement Procedure

1. Set pump upside down (remove filter cover for stability if required), unscrew and remove all upper housing screws. Then return pump to upright position and lift away upper housing.
Housing screw counts: AL-30~80 (4x), AL-100~200 (6x), AL-250~500 (12x)
2. Carefully uncouple and detach the L-tube (rubber elbow) from discharge port of each diaphragm housing.
3. Select a diaphragm housing on core frame, remove its 4 corner screws, then pull housing away. Proceed to remove the hex nut and washer from center of the diaphragm plate then pull and slide the entire diaphragm block away from magnetic bar and core frame.
4. Select a new diaphragm block from the DRK, align shape with core frame and magnetic bar then slide over the rod screw. Secure assembly firmly with washer and hex nut. Apply 1 to 2 drops of removable grade threadlocker between the hex nut and protruded rod screw.
5. Install new diaphragm housing then secure with 4 corner screws.
6. Attach L-tube (rubber elbow) to the discharge port of the new diaphragm housing then secure with silicone band or clamp.
7. Repeat step #3 through #6 on opposite side.
IMPORTANT: Do not mix old and new parts. For reliable operation, always replace both diaphragm modules in the pump at the same time.
8. Inspect the position of magnetic bar from the top. The bar should be centered and does not make any contact with any of the two electromagnets.
9. If the pump includes a protective switch on top of the pump core, slide and align the switch to the ON position. (See illustration)
10. Reinstall upper pump housing, check to avoid jamming any power wires, then secure firmly with all housing screws.

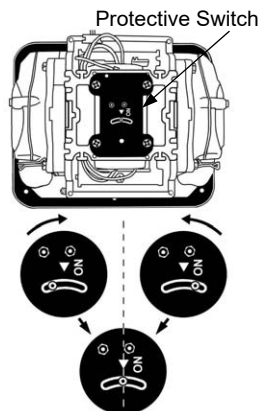

In case of unusual noise or odor from the pump, turn off the power immediately, consult the maintenance guide, or contact your nearest pump representative or Alita service department for assistance.

REPLACEMENT PARTS LIST

Except for vacuum models, in general diaphragm replacement kit includes air filter pad and filter cover packing.

MODEL \ PARTS	DIAPHRAGM REPLACEMENT KIT	MAGNETIC BAR
AL-30 / 40 / 40P	DRK40	MR40
AL-40SA (Vacuum)	DRK40S	
AL-50 / 60 / 60P	DRK60	MR60
AL-60SA (Vacuum)	DRK60S	
AL-80 / 80P / 100P	DRK80	
AL-80SA (Vacuum)	DRK80S	
AL-100	DRK120	
AL-120	DRK120	MR120
AL-125	DRK150	MR200
AL-150 / 200 / 250E	DRK250	
AL-250	DRK120X2	MR120 (2X)
AL-300 / 350 / 400 / 500	DRK250X2	MR200 (2X)

For customized or special pump models, please check for specific parts information attached separately.

Assembly Diagram for Models AL-40 ~ AL-80

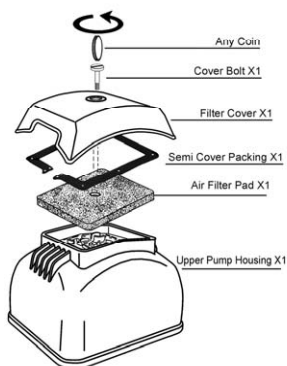

AL-40~60~80
Upper housing exploded view

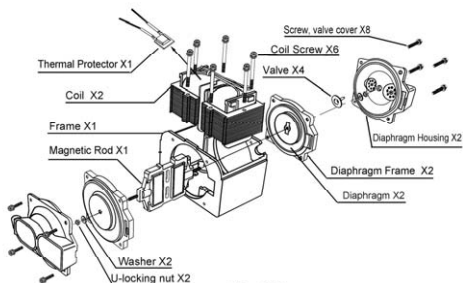

AL-80
Internal components exploded view

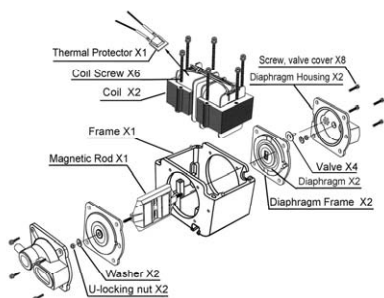

AL-40
Lower housing exploded view

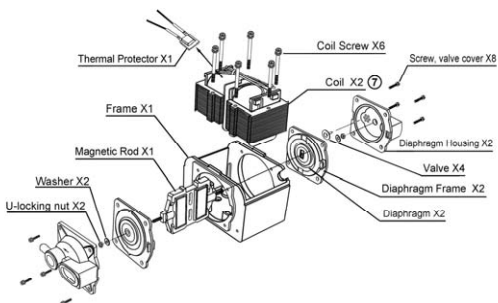

AL-60
Internal components exploded view

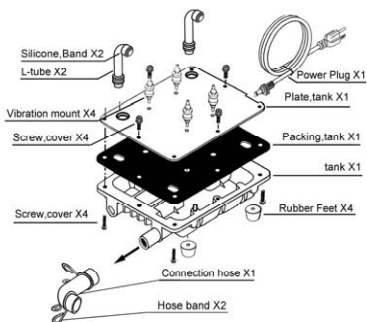

AL-40~60
Lower housing exploded view

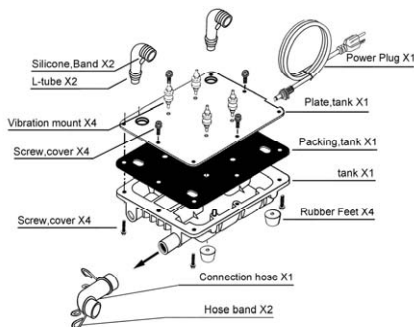

AL-80
Lower housing exploded view

Assembly Diagram for Models AL-100 ~ AL-500

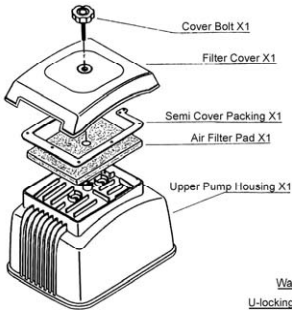

AL-100~200~500
Upper housing exploded view

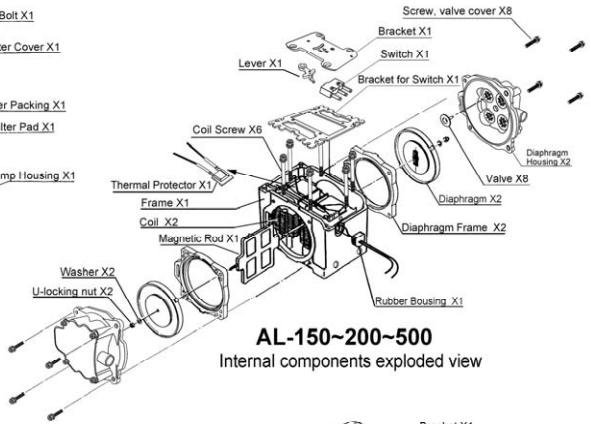

AL-150~200~500
Internal components exploded view

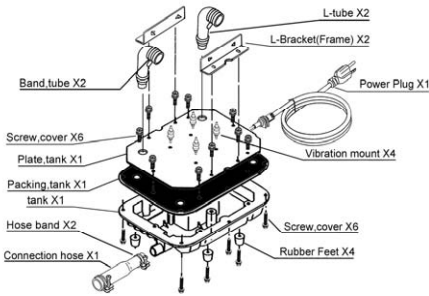

AL-100~120
Lower housing exploded view

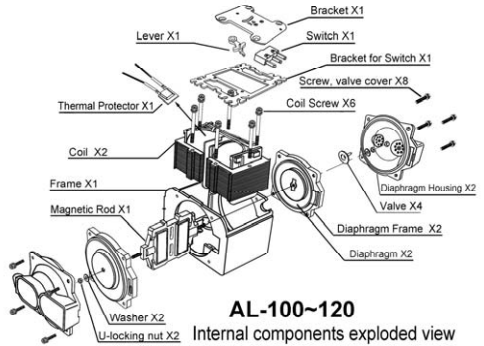

AL-100~120
Internal components exploded view

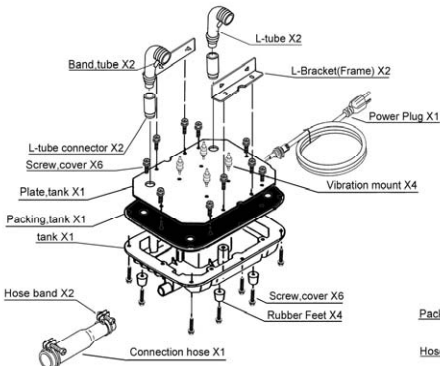

AL-150~200
Lower housing exploded view

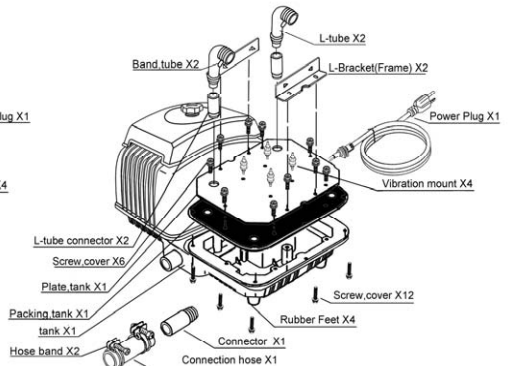

AL-250~500
Lower housing exploded view

TROUBLESHOOTING GUIDE

- ❖ Pump does not start
 - Poor electrical connection: Plug securely into AC outlet.
 - Power cord damage: Contact ALITA for repair service.
 - GFCI tripped: Check for moisture/water on plug or water inside the pump. Replace any faulty GFCI.

- ❖ There exist a high humming or hissing noise
 - High backpressure: Reduce operating pressure load.
 - Undersized plumbing: Check Plumbing instructions.

- ❖ Pump turns off and on randomly
 - High thermal stress: Check Proper Ventilation instructions. Improve heat dissipation rate for more reliable and durable operation. Allow thermal protection to auto reset after cooling.

- ❖ Reduced flow rate or performance (after long period of usage)
 - Faulty air distribution medium: Replace clogged or damaged air line, clean air control valves or release bends in flexible tubing.
 - Pump intake blocked: Remove blockage from pump intake.
 - Fouled air diffusers: Replace or clean air diffuser thoroughly.
 - Worn diaphragms: Replace aged or damaged diaphragm modules.
 - Demagnetized magnetic bar: Replace with new magnetic bar.

- ❖ Pump produces abnormal noises (after long period of usage)
 - Diaphragm failure: Stop pump operation immediately. Open pump and check condition of magnetic bar. Procure replacement parts for repair.

- ❖ Pump stops and will not restart (after long period of usage)
 - Diaphragm failure, magnetic bar adhere to an electromagnet: Open pump and check condition of magnetic bar. Procure diaphragm replacement kit for maintenance.
 - Protective Switch activated in models AL-100~500 and certain models of AL-60~80: Procure diaphragm replacement kit for maintenance. Reset Protective Switch after repair.

If none of the prescribed solution help resolve the pump problem, contact ALITA for repair service instructions. **DO NOT ATTEMPT** repair beyond diaphragm module and magnetic bar replacement.

LIMITED WARRANTY

ALITA warrants to the original retail consumer purchaser ("Customer") that the ALITA product, when properly installed and operated under normal conditions of use, will be free from defects in materials and workmanship for a period of three (3) years from the date of purchase from ALITA or an authorized ALITA representative. This warranty applies only to ALITA products installed in the United States of America and Canada. Customer is responsible for registration of product warranty and maintaining a dated proof of purchase, and such registration and proof shall be used to determine warranty eligibility.

ALITA Limited Warranty covers only those defects which arise as a result of normal use of the product and do not apply to any: (a) defect or malfunctions resulting from failure to properly install, operate or maintain the ALITA product in accordance with printed instructions provided; (b) failures resulting from abuse, accident or negligence; (c) ALITA product which is not installed in accordance with applicable local codes, ordinances and good trade practices; (d) operation outside the ALITA product's specifications or used for purposes other than for what it was designed and manufactured; (e) improper or inadequate maintenance or modification, and (f) damage due to shipment, lightning, natural disaster, earthquake, fire, flood, force majeure or circumstances beyond the control of ALITA.

If within the duration of Limited Warranty, the ALITA product shall prove to be defective due to defective materials or workmanship of ALITA, ALITA shall either repair or replace the defective product, at ALITA's option. ALITA shall have no obligation to repair or replace until the Customer returns the defective product, together with dated proof of purchase and written notice of alleged defect to ALITA. Customer may be required at ALITA's request to verify that he or she is the original purchaser of the ALITA product and the ALITA product has been installed and operated in accordance with ALITA's instructions. Any replacement product may be either new or like-new, provided that it has functionality at least equal to that of the product being replaced. No requests for service under this warranty will be accepted if received more than 30 days after the term of the warranty.

ALITA shall be liable only for the cost of the replacement part, or the repair of any defective part. Customer shall be responsible for labor, cost of removal and installation at Customer's premises, transportation and insurance cost to and from ALITA, and any other incidental costs.

Correction of defects, in the manner and for the duration of the warranty described in this Limited Warranty, shall constitute complete fulfillment of all liabilities and responsibilities of ALITA to the Customer with respect to the product, and shall constitute full satisfaction of all claims, whether based on contract, negligence, strict liability or otherwise.

Except for the obligations specifically set forth in this Limited Warranty, in no event shall ALITA be liable for direct, indirect, special, incidental, or consequential damages, whether based on contract, tort, or any other legal theory and whether advised of the possibility of such damages.

ALITA disclaims all other warranties with respect to ALITA product, whether implied, and specifically disclaim the implied warranties or conditions of merchantability, satisfactory quality, fitness of a particular purpose.

Unauthorized extensions of warranties by the customer shall remain customer's responsibility.

ALITA reserves the right to change or improve its products or any portions thereof without being obligated to provide such a change or improvement for units sold and/or shipped prior to such a change or improvement.

The limited warranties described herein shall be the sole and exclusive remedy available to the Customer. This warranty is void if the ALITA product has been improperly used, mishandled, disassembled or modified.

Customer is responsible for determining the suitability of ALITA products for customer's use or resale or for incorporating them into objects or applications which customer designs, assembles, constructs or manufactures.



ALITA INDUSTRIES, INC.
PO Box 660923, Arcadia, CA 91066-0923, USA
Phone: (626) 962-2116 On-Line: www.alita.com E-mail: info@alita.com